

PRODUCT INFORMATION PACKET

Model No: 056T17V99008
Catalog No: N355
3/4,1800,TENV,56C,3/60/208-230/460
Washdown Duty

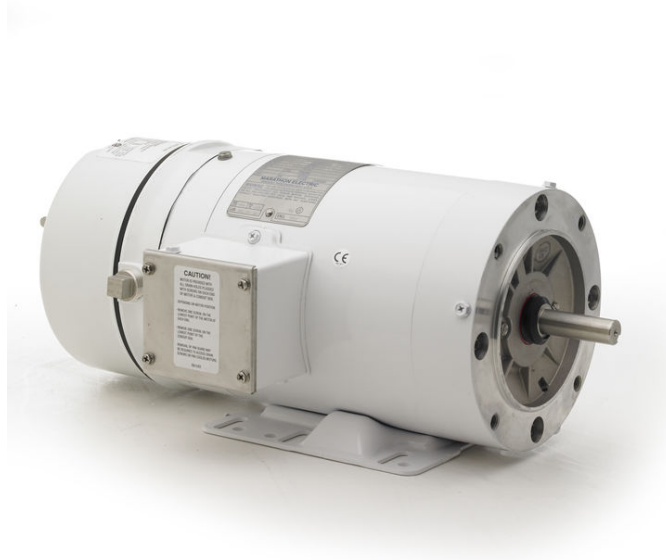

Regal and Marathon are trademarks of Regal Beloit Corporation or one of its affiliated companies.
©2018 Regal Beloit Corporation, All Rights Reserved. MC017097E





Nameplate Specifications

Output HP	0.75 Hp	Output KW	0.56 kW
Frequency	60 Hz	Voltage	208-230/460 V
Current	2.7-2.5/1.3 A	Speed	1725 rpm
Service Factor	1.15	Phase	3
Efficiency	80 %	Duty	Continuous
Insulation Class	F	Design Code	B
KVA Code	L	Frame	56C
Enclosure	Totally Enclosed Non Ventilated	Overload Protector	No
Ambient Temperature	40 °C	Drive End Bearing Size	6205
Opp Drive End Bearing Size	6203	UL	Recognized
CSA	Y	CE	Y
IP Code	55		

Technical Specifications

Electrical Type	Squirrel Cage Induction Run	Starting Method	Across The Line
Poles	4	Rotation	Reversible
Mounting	Rigid base	Motor Orientation	Horizontal
Drive End Bearing	Ball	Opp Drive End Bearing	Ball
Frame Material	Rolled Steel	Shaft Type	NEMA 56
Overall Length	15 in	Frame Length	6.00 in
Shaft Diameter	0.625 in	Shaft Extension	1.94 in
Assembly/Box Mounting	F1 Only		
Outline Drawing	607-0145-600	Connection Diagram	005010.15ME

This is an uncontrolled document once printed or downloaded and is subject to change without notice. Date Created: 06/29/2018

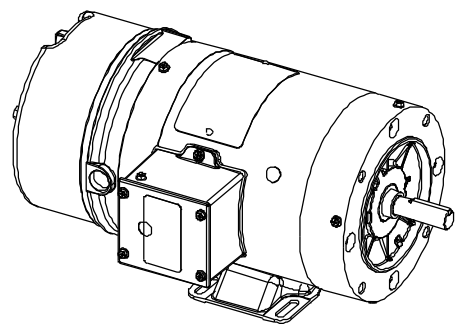
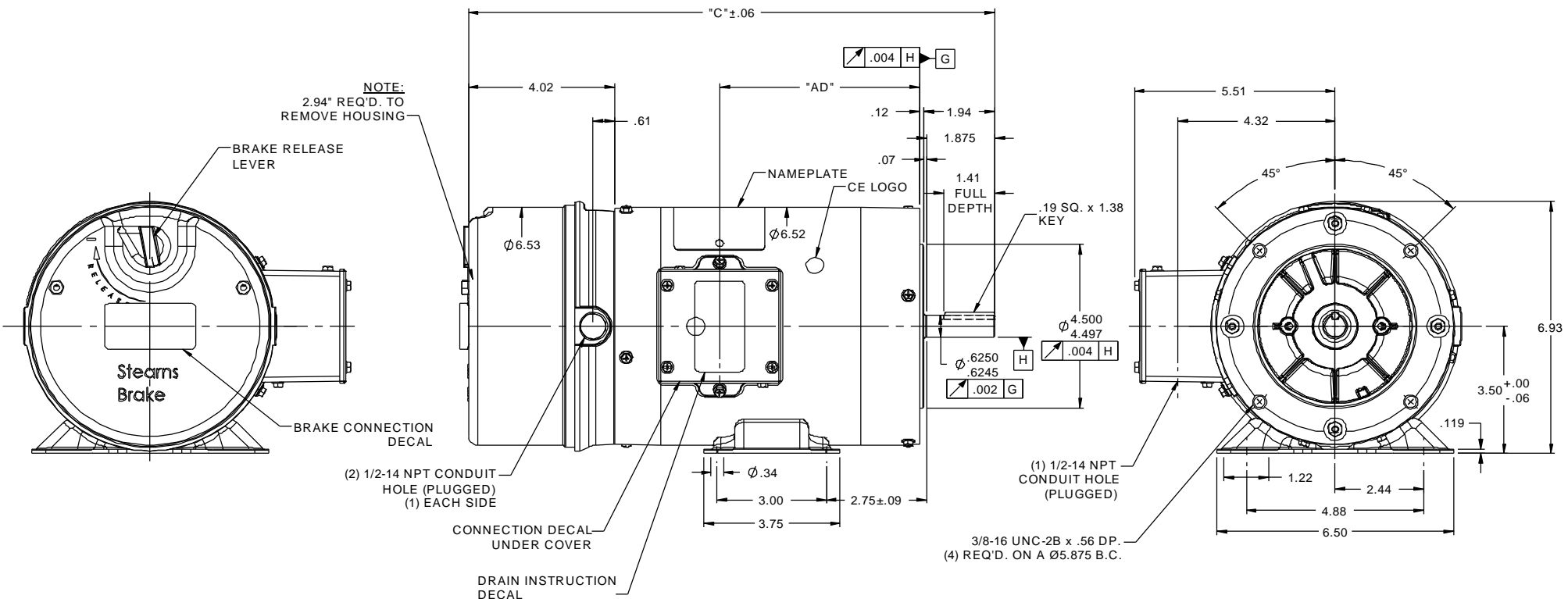

WASHGUARD FEATURES:

- 1) SHAFT SEAL & V-RING
- 2) PLUGGED DRAIN HOLES IN ENDBELLS & CONDUIT BOX
- 3) STAINLESS STEEL SHAFT, HARDWARE, & NAMEPLATE
- 4) GASKETS THROUGHOUT

DASH NO.	"C"	"AD"
500	14.00	5.01
550	14.50	5.51
600	15.00	6.01
650	15.50	6.51

NO		REVISION	BY & DATE	CHK	LANG	±1/2°	FINISH	marathon electric		DRAWN	PVR	12/31/12
								marathon electric		CHK	JD	12/31/12
								marathon electric		APPR		
								marathon electric		SCALE	3:8	
								marathon electric		REF	028575.00	
								marathon electric		FMF	056T17V99007	
								marathon electric		PAGE	OF	
								marathon electric		SIZE	B	
								marathon electric		DRAWING NO	607-0145	
								marathon electric		REV		

VIEW FROM OUTSIDE OF MOTOR AT SWITCH END.

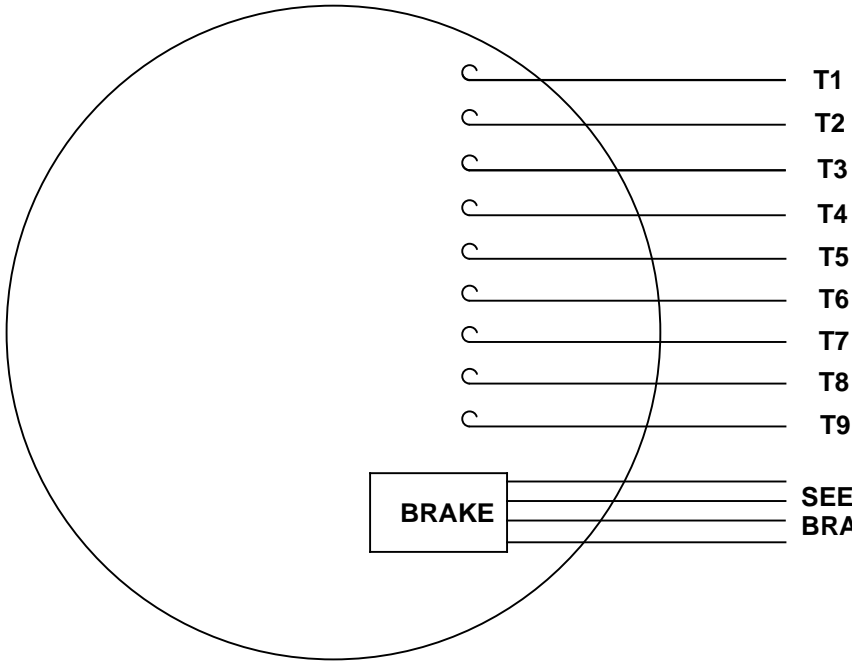

T1
T2
T3
T4
T5
T6
T7
T8
T9

BRAKE

**SEE TABLE FOR
BRAKE CONNECTIONS**

LINE LEADS

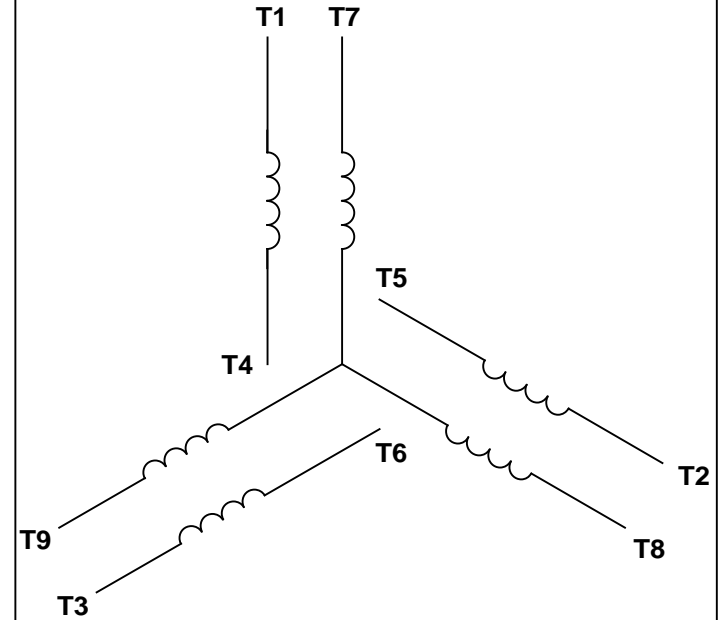

VOLTAGE	L1	L2	L3	JOIN & INSULATE
HIGH	T1	T2	T3	(T4, T7) (T5, T8) (T6, T9)
LOW	T1, T7	T2, T8	T3, T9	T4, T5, T6

RBC PROPRIETARY AND CONFIDENTIAL INFORMATION
This document is the property of REGAL BELOIT CORPORATION ("RBC") including its subsidiaries and divisions and contains proprietary information of RBC. This document is loaned on the express condition that neither it nor the information contained therein shall be disclosed to others without the express written consent of RBC, and that the information shall be used by the recipient only as approved expressly by RBC. This document shall be returned to RBC upon its request. This document may be subject to certain restrictions under U.S. export control laws and regulations.

BRAKE CONNECTION

VOLTAGE	STERNS BRAKE			DINGS BRAKE		
	L1	L2	Join	L1	L2	Join
HIGH	1(RE D)	2(RE D)	3(BLACK) 4(BLACK)	2(BLACK)	4(YELLOW)	1(YELLOW) 3(BLACK)
LOW	1(RE D) 3(BLACK)	2(RE D) 4(BLACK)	-----	2(BLACK) 3(BLACK)	1(YELLOW) 4(YELLOW)	-----

		TOLERANCES UNLESS SPECIFIED				DRAWN MDN 03/26/03	
		DEC	INCHES			CHK	
		.X	±.1			APPR	
		.XX	±.01			SCALE 1:1	
		.XXX	±.005	TITLE EXTERNAL WIRING DIAGRAM 3 PHASE W/O PROTECTOR		REF	
--	REDRAWN IN SOLIDWORKS	VJB 02/08/11	.XXXX	±.0005	MAT'L MTR DECAL - 004014 BRAKE DECAL - 080034		FMF
NO	REVISION	BY & DATE	CHK	ANG ±1/2°	FINISH		PAGE OF
THIRD ANGLE PROJECTION			RFP	PREV	SIZE	DRAWING NO	
			NETWORK FILE NAME 00501015ME			A	005010-15ME
							REV
							--

FORM 3531 REV.3 02/07/99
** Subject to change without notice.